

**STEAB**

Via Ugo Corti, 18 - 00141 FIRENZE - ITALIA - Tel. 055-419988 r.a. - Fax. 055-419989 - www.steab.it

ALLEGATO TECNICO Technical data sheet

Codice documento:

SC-ALLT Rev.0

Rif./des.

Paguro® 5660/3**DISPOSITIVO DI GIUNZIONE IP-68****JUNCTION DEVICE IP-68****A1**

Per cavi \varnothing est. min.13+ MAX 16
senza l'uso dell'adattatore
Per cavi \varnothing est. min.10.5 + MAX 13
con l'uso dell'adattatore (bianco)
Per cavi \varnothing est. min.7.5 + MAX 10.5
con l'uso dell'adattatore (grigio)

For cables \varnothing ext. min. 13 + MAX 16
without using the adapter
For cables \varnothing ext. min. 10.5 + MAX 13
using of the adapter (white)
For cables \varnothing ext. min. 7.5 + MAX 10.5
using of the adapter (gray)

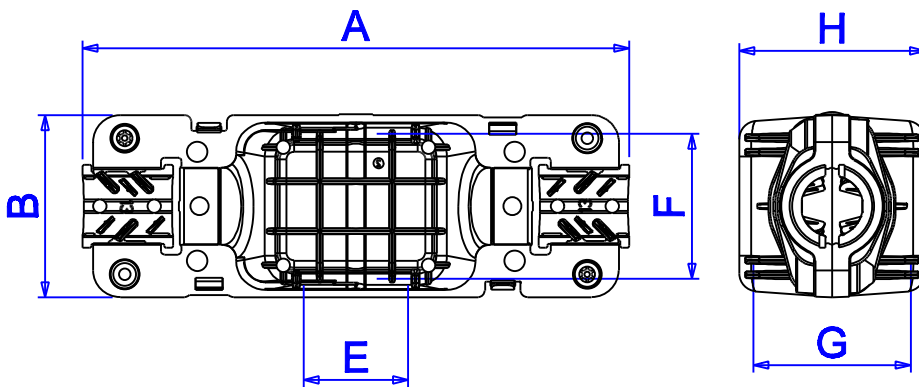
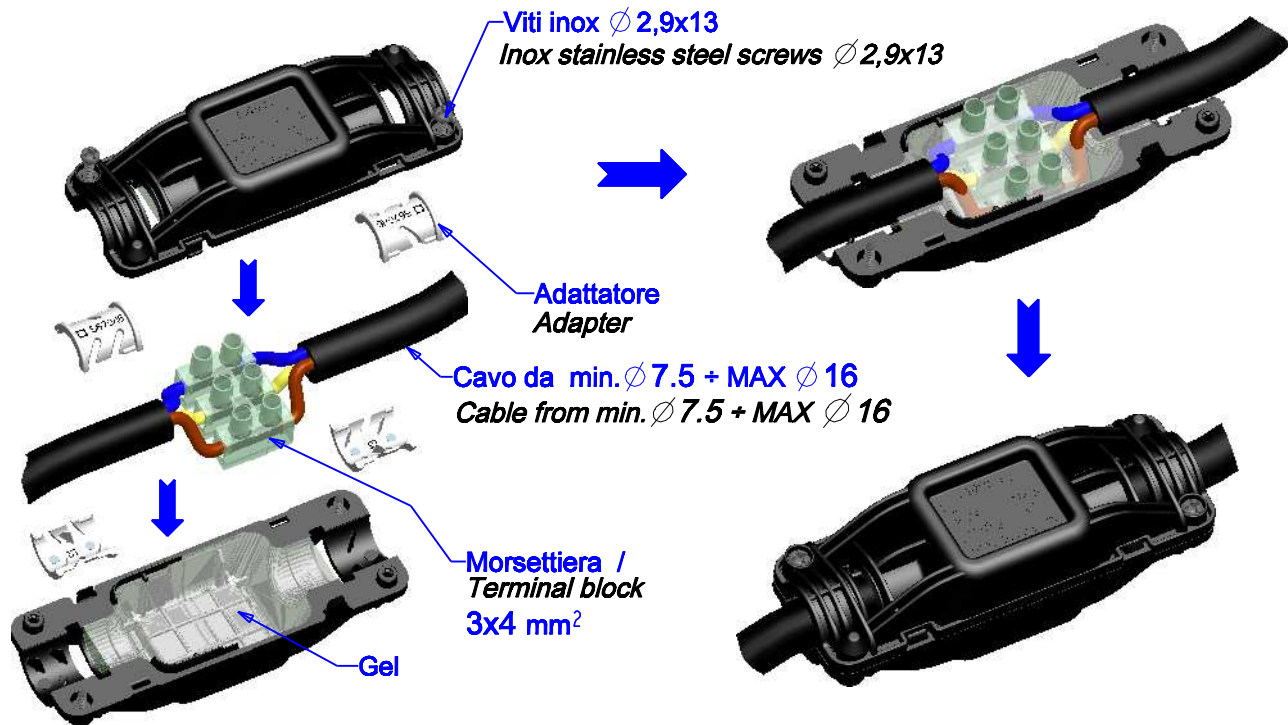

Schema
sguainatura cavo
Cable's
dismantling specs

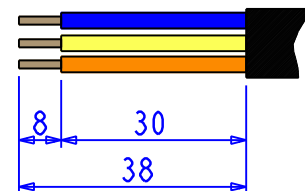

ExFxG Max volume interno disponibile
ExFxG Max internal room available

Codice Code	Dimensioni / Dimensions (mm)							Materiale Material	Colore/Colour	
	A	B	D	E	F	G	H		2	Nero Black
5660/3	**	40	**	35	32	27	41	2	2	1

** Se si utilizza per cavi da 13 a 16 A=116
Se si utilizza per cavi da 7.5 a 13 A=120

** With cables from 13 to 16 A = 116
With cables fs from 7.5 to 13 A = 120